

NEXT DUO

Dual-Technology, Digital MW/PIR Intrusion Detector



Visonic

Installation Instructions

1. INTRODUCTION

The NEXT DUO is a digital, microprocessor-controlled MW / PIR detector that can be adapted to the size of the protected area by use of a **model selector**. A different digital signal processing (DSP) is used upon selection of each model, thus optimizing both PIR and MW performance within the protected area.

The PIR section of the NEXT DUO employs a cylindrical lens with uniform detection sensitivity beginning at 0.5 m (1.8 ft) away from the detector up to a distance of 12 meters (40 ft). Advanced **True Motion Recognition™** algorithm (patented) allows the NEXT DUO to distinguish between the true motion of an intruder and any other disturbances which cause false alarms.

A Test input permits switching the detector to the walk test mode remotely without removing the front cover. An on-board motion event jumper determines whether 1 or 2 consecutive motion events would trigger an alarm.

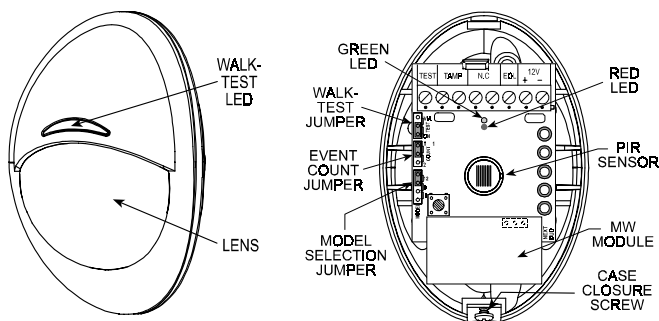

Figure 1. General View

Figure 2. Inside View

2. SPECIFICATIONS

Selectable Models: Models covering 6, 9 and 12 meters (20, 30 and 40 ft), selected upon installation

Input Voltage: 9 to 16 VDC

Current Drain: About 20 mA @ 12 VDC

PIR SECTION (see Figure 3)

Lens Data

No. of Curtain Beams: 9 + 5

Max. Coverage: 12 x 12 m (40 x 40 ft) / 90°

Tripping Indication: Indicator lights ORANGE for about 3 sec.

MW SECTION

Oscillator Type: Microstrip, DRO-stabilized

Frequency: 2.45 GHz

Detection Range: Up to 12 m

Tripping Indication: Indicator lights GREEN for about 3 sec.

ALARM and TAMPER

Alarm Output: Solid-state relay, N.C., up to 100 mA / 30 V, ~30 Ω internal resistance. Circuit opens for 2-3 seconds upon alarm.

Alarm Indication: Indicator lights RED for about 3 seconds.

Event Counter: Selectable, 1 or 2 motion events

Tamper Contacts: Normally closed, 50 mA resistive / 30 VDC

MOUNTING

Surface or corner, at the height of 1.8 to 2.4 m (6 to 8 ft)

Note: Base allows single-sided corner mount at 45° to wall.

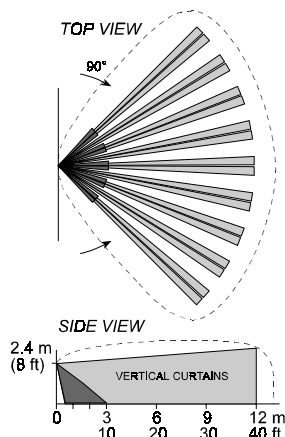

Figure 3. Maximum Coverage Pattern

ACCESSORIES:

BR-1: Surface mounted swivel bracket, adjustable 30° down and 45° left/45° right.

BR-2: BR-1 with a corner adapter

BR-3: BR-1 with a ceiling adapter

ENVIRONMENTAL

Operating Temperature: -10°C to 50°C (14°F to 122°F)

Storage Temperature: -20°C to 60°C (-4°F to 140°F)

RFI Protection: Greater than 20 V/m (20 MHz to 1000 MHz)

PHYSICAL

Size (H x W x D): 94.5 x 63.5 x 49.0 mm (3-11/16 x 2-1/2 x 1-15/16")

Weight: Approximately 50 g (1-3/4 oz)

PATENTS: U.S. Patents 5,693,943 • 6,211,522 • D445,709 (another patent pending)

This device complies with the essential requirements and provisions of Directive 1999/5/EC of the European Parliament and of the Council of 9 March 1999 on radio and telecommunications terminal equipment. 2.45 GHz has no restriction in any EU member state.

The term "IC" before the certification number **IC: 1467A - NEXTDUO** (that is printed on the detector) signifies that the Industry Canada technical specifications were met.

To comply with the Canadian standard RSS-210, this device must be operated **indoors only** to provide maximum shielding and to prevent interference to licensed services.

3. INSTALLATION

3.1 General Guidelines

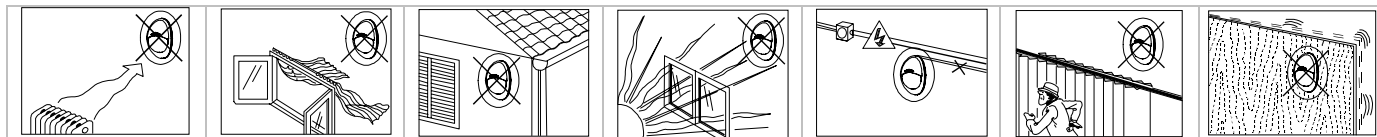

A. Microwave radiation passes through glass and non-metallic walls. Be sure, therefore, to select the correct model in accordance with the room size. This is important to minimize the effect of movements occurring beyond room limits which might cause the MW section to trip.

B. Large reflecting objects (especially metals) in the coverage area can distort the microwave detector's coverage pattern.

C. If two NEXT-DUO units are installed in the same room or on opposite sides of a shared wall, they should not face each other and must be mounted at least 20 cm (0.6 ft) apart.

Attention! At power up, the detector undergoes a 60-second stabilization period, indicated by alternate flashing of the red and green LEDs.

3.2 Illustrated Installation Procedure

1 Disassemble unit

2 Open holes in base

3 Mount base

1.8 - 2.4 m (6 - 8 ft) above ground

4 Set jumpers as needed

5 Wire up the terminal block

6 Walk-test the coverage area

4. SPECIAL COMMENTS

Even the most sophisticated detectors can sometimes be defeated or may fail to warn due to: DC power failure / improper connection, malicious masking of the lens, tampering with the optical system, decreased sensitivity in ambient temperatures near that of the human body and unexpected failure of a component part.

The above list includes the most common reasons for failure to detect intrusion, but is by no means comprehensive. It is therefore recommended that the detector and the entire alarm system be checked weekly, to ensure proper performance.

An alarm system should not be regarded as a substitute for insurance. Home and property owners or renters should be prudent enough to continue insuring their lives and property, even though they are protected by an alarm system.

This device has been tested and found to comply with the limits for a Class B digital device, pursuant to Part 15 of the FCC Rules. These limits are designed to provide reasonable protection against harmful interference in residential installations. This equipment generates, uses and can radiate radio frequency energy and, if not installed and used in accordance with the instructions, may cause harmful interference to radio and television reception. However, there is no guarantee that interference will not occur in a particular installation. If this device does cause such interference, which can be verified by turning the device off and on, the user is encouraged to eliminate the interference by one or more of the following measures:

- Re-orient or re-locate the receiving antenna.
- Increase the distance between the device and the receiver.
- Connect the device to an outlet on a circuit different from the one that supplies power to the receiver.
- Consult the dealer or an experienced radio/TV technician.

WARNING! Changes or modifications to this unit not expressly approved by the party responsible for compliance could void the user's authority to operate the equipment.



VISONIC LTD. (ISRAEL): P.O.B 22020 TEL-AVIV 61220 ISRAEL. PHONE: (972-3) 645-6789, FAX: (972-3) 645-6788
 VISONIC INC. (U.S.A.): 10 NORTHWOOD DRIVE, BLOOMFIELD CT. 06002-1911. PHONE: (860) 243-0833, (800) 223-0020 FAX: (860) 242-8094
 VISONIC LTD. (UK): FRASER ROAD, PRIORY BUSINESS PARK, BEDFORD MK44 3WH. PHONE: (0870) 730-0800 FAX: (0870) 730-0801
 INTERNET: www.visonic.com

©VISONIC LTD. 2003 NEXT DUO DE1834- (REV. 3, 1/03)

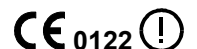

MADE IN ISRAEL